

Constellation On-Board Computer

The Constellation On Board Computer (cOBC) is a complete subsystem entirely based on commercial components to enable high performance and short lead times at an affordable price, still delivering the high reliability Beyond Gravity is well known for. The cOBC provides a host of functions including on-board processing, GNSS receiver, ground communication and both platform and payload interfaces. The computer is fully redundant and offers flight proven fault detection, isolation, and recovery (FDIR) as well as radiation mitigation to provide a highly reliable solution.

Key Features

- Highly reliable solution with **dual redundant architecture** and support for long missions in LEO, MEO and GEO.
- Extensive functions and flexible I/O support, integrating OBC, RTU and GNSS receiver functions into **one unit**.
- Manufacturing highly automated and optimized for **large quantities**.
- Optional **integrated GNSS receiver**, NavRIX Integral, with support for GPS and Galileo including harness and antennas. Accuracy of down to 1m 3D RMS.
- **Full TM/TC** chain compliant to CCSDS format including optional AES256 encryption/decryption and authentication.

Main Functions

- Processing Function
- Extensive and flexible digital I/O
- Analogue / AOCS interfaces
- Full Telecommand/Telemetry stack (CCSDS)
- Automatic and programmable reconfiguration function in hardware
- Safe-guard memory
- On-board time keeping in synch with GNSS

Options & Configuration

- GNSS support
- TM/TC authentication, encryption and decryption
- Secure boot
- Interface counts and configuration
- Number of PDIO boards *
- Number of PROPE boards *
- Operating System: VxWorks, RTEMS or Linux

* See next page and dedicated datasheets.

Standard Offerings

- **Development Kit**
 - All you need to start SW development
 - HW fully representative of digital parts

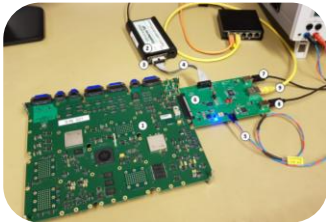

- **Engineering Models**
 - Fully representative units
 - Redundant or non-redundant



- **Qualification Package**
 - Analyses, reports and process documentation to prove stated cOBC quality

- **Flight Units**
 - According to the defined configuration
 - From a single unit to hundreds

- **Partner Offerings**

- **MAX FSX Toolbox** (by RocketLab)

- Flight, simulation and operational SW suite
 - <https://rocketlabcorp.com/space-systems/space-software/>

- **TERMA cOBC Simulator** (by Terma)

- Accurate simulator for SW development and verification as well as operations simulation



Processing function

- Power Architecture ©
 - 2x e500Core @ 800 MHz
 - 3600 DMIPS
 - 1600 MFLOPS
 - 32 KB L1 instruction cache
 - 32 KB L1 data cache
 - 512 KB L2 cache
- 1 GiB DDR3 processing memory with ECC
- 2.7 GiB non-volatile storage with ECC

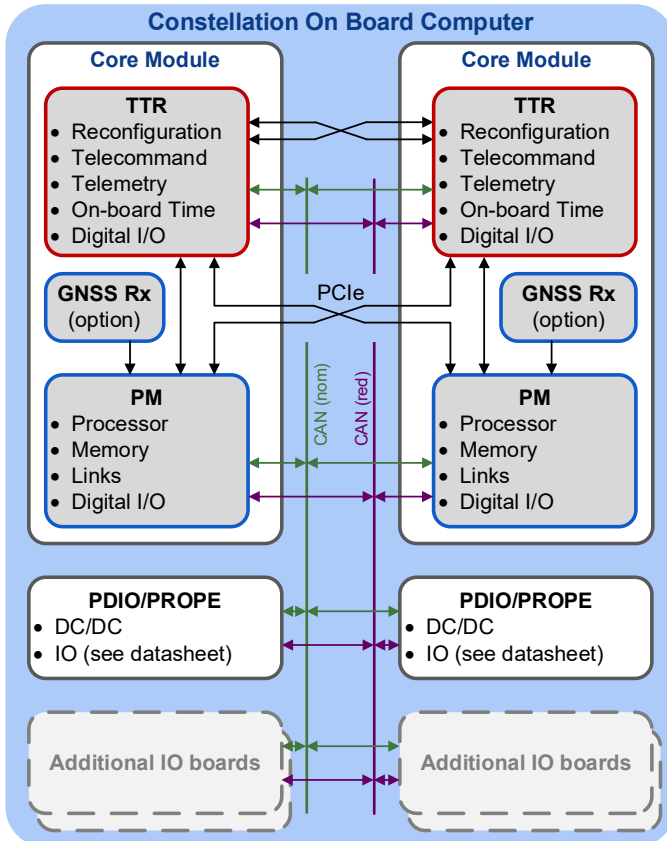

Software

- BSP for VxWorks, RTEMS or Linux
- Driver SW API towards all HW functions
- Boot Software, including Standby Mode

Reliability

- Reliability: 99% (10 years, 30°C base plate)
- No single-point failures
- Fully dual-redundant architecture

Environment

- Temperature -20 to +60°C
- Random vibration 15g RMS
- Shock 2000g @ 2000Hz

Contact our sales team for more information:

Core Digital Interfaces

- 2 x 2 TM Encoder RS422
- 2 x 2 TC Decoder RS422
- 2 x 1 Ethernet interfaces
- 2 x 6 SpaceWire links (2x1 hot powered)
- 2 x 3 CAN buses
- 2 x 18 RS422/RS485 UART interfaces
- 2 x 16 GPIO
- 2 x 4 Sync Pulse output
- 2 x 1 Separation strap inputs
- 2 x 2 External alarm inputs
- 2 x 1 External Cryptographic Unit (option)

Additional I/O

- Optional number of PROPE/PDIO boards
- Standard Power and Drive (PDIO) boards *
 - Analogue Acquisition
 - Digital and Relay Status
 - Temperature Acquisition
 - Secondary Voltages
 - Stepper Motors
 - Magnetorquers
 - Magnetometers
 - Sun Sensors
 - Pulse Commands
- Standard Chemical Propulsion (PROPE) boards *
 - Heater Control
 - Temperature Acquisition
 - Pressure Transducer
 - Latch Valves
 - Flow Control Valves
- Custom I/O boards

* See dedicated fact sheets for PDIO and PROPE board capabilities

GNSS option

- Tracks GPS L1 C/A and Galileo E1 B/C signals and provides position, velocity and time
- Accuracy down to 1m 3D RMS with use of dynamic filtering
- Pulse Per Second (PPS) time error < 100ns RMS
- Operation without need of external LNA

Above performances guaranteed in LEO orbit

*) See dedicated datasheet for NavRIX Integral capabilities

SWaP

- Volume 300 x 119 x 239 mm³ (excluding feet)
- Power consumption ~26W (nominal)
- Mass 5.4 kg

ake.jendeby@beyondgravity.com
mathias.kremer@beyondgravity.com